

# MultiCooler

## Portable Refrigerator and Freezer

### User Manual

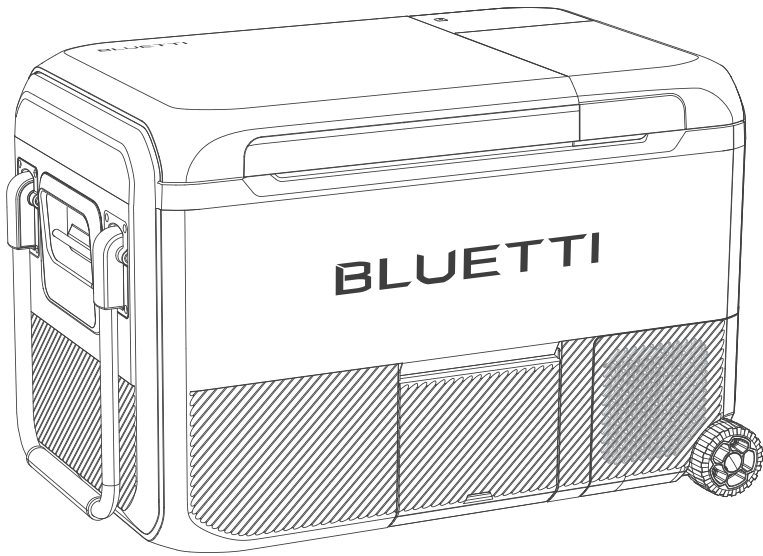



# Contents

<b>1</b>	<b>Safety Instructions</b> .....	<b>04</b>
<b>2</b>	<b>Specifications</b> .....	<b>07</b>
<b>3</b>	<b>Packing List</b> .....	<b>09</b>
<b>4</b>	<b>Power Supply Connection</b> .....	<b>10</b>
4.1	AC Mains .....	10
4.2	RV Cigarette Lighter .....	10
4.3	B70 Battery .....	11
4.4	Solar Panel (with battery inside) .....	12
<b>5</b>	<b>Lid Removal</b> .....	<b>12</b>
<b>6</b>	<b>Water Volume (for ice-making)</b> .....	<b>12</b>
<b>7</b>	<b>Refrigerator Compartment Operation</b> .....	<b>13</b>
<b>8</b>	<b>Ice-Making Compartment Operation</b> .....	<b>14</b>
<b>9</b>	<b>BLUETTI App</b> .....	<b>16</b>
9.1	Download .....	16
9.2	Sign up .....	16
9.3	Log in .....	17
9.4	Bluetooth Connection .....	18
<b>10</b>	<b>Tilt Protection</b> .....	<b>19</b>
<b>11</b>	<b>Troubleshooting</b> .....	<b>19</b>
<b>12</b>	<b>Storage Tips</b> .....	<b>20</b>
<b>13</b>	<b>FCC Warning</b> .....	<b>21</b>
<b>14</b>	<b>Warranty Policy</b> .....	<b>22</b>

## Disclaimer

Please read this manual carefully before use and keep it for future reference. Failure to operate the product correctly may result in serious injury to yourself or others, as well as damage to the product and property loss. By using this product, you acknowledge and accept all the terms and contents of this manual.

The interpretation of this manual and any related materials is solely at the discretion of BLUETTI, subject to compliance with all applicable laws and regulations. Kindly be informed that BLUETTI reserves the right to update, revise, or terminate this manual and any related materials without further notice. For the most up-to-date version, please visit: <https://www.bluettipower.com/pages/user-guides>

## 1. Safety Instructions

Read this manual for instructions on the proper use and safety information for the product.



### **Danger!**

#### **Risk of Electric Shock**

- If the product is visibly damaged, do not operate it and disconnect all electrical connections immediately.
- In case of a damaged power cable, have it replaced by the manufacturer, its service agent or a similarly qualified personnel to minimize potential safety risks.
- Avoid direct contact with exposed cables to prevent injury.
- Before starting the product, make sure that the power cable is dry and not frayed, cracked, or otherwise damaged. Fully insert its plug into an appropriate outlet.
- Disconnect the power supply before cleaning and maintenance.

#### **Risk of Fire**

- Do not use the product with the power cable knotted or bundled.
- Do not locate multiple portable socket-outlets or portable power supplies at the rear of the product.
- Keep the ventilation openings in the unit casing or built-in structure free of obstacles.
- Do not use mechanical devices or other means to accelerate the defrosting process.
- Take care not to damage the refrigerant circuit.

## **Risk of Child Entrapment**

- The product is not intended for use by individuals (including children) with reduced physical, sensory, or mental capabilities, or lack of experience and knowledge, unless they are supervised or instructed by a responsible person regarding the safe use of the product.
- Do not allow children to play on or in the product.
- Close supervision is necessary if children attempt to clean or maintain the product.
- Before disposing of your old refrigerator:
  - Remove the doors.
  - Leave shelves or internal parts in place to prevent children from getting inside.
- Keep children away from packaging materials, such as folded cardboard or plastic film, as they may pose a choking hazard.

## **Risk of Explosion**

- Do not store any explosive substances like spray cans with a flammable propellant.



## **Notice**

- Only use potable water for making ice.
- To prevent food or medicine contamination or spoilage, follow these instructions:
  - Check if the product's cooling capacity is suitable for storing the food or medicine.
  - Store food only in its original packaging or in suitable containers.
  - Avoid leaving the door open for long periods, as this can cause the temperature inside the compartment to rise significantly.
  - Regularly clean surfaces that can come in contact with food and accessible drainage systems.
- If the product is to be left empty for long periods, follow these instructions:
  - Power it off.
  - Defrost completely.
  - Clean and dry the interior.
  - Leave the door open to prevent the formation of mold or unpleasant odors.
- When handling the product, grasp the handles located on the sides or use the draw bar.
- Check if the voltage specified on the nameplate matches that of the power supply.
- Connect the product to the vehicle's DC power source using the provided car charging cable.

- Make sure to unplug the product by pulling the plug rather than the cable.
- When the plug is disconnected, leave it for 10 seconds before plugging it in again. Failure to do so may result in the product not functioning properly.
- Do not put your hands or any metal objects into the ventilation openings.
- Do not reach into the ice-making compartment while it's active.
- The product is not suitable for storing corrosive or solvent-containing materials.
- The product contains flammable cyclopentane and requires special care when disposing of it. When it reaches the end of its service life, please take it to an appropriate recycling center.
- Do not use electrical appliances inside the food storage compartments of the appliance, unless they are of the type recommended by the manufacturer.
- Do not place the appliance near naked flames or other heat sources (heaters, direct sunlight, gas ovens, etc.)
- **Danger of overheating!**
  - Make sure that there is always a minimum of 2 inches (50mm) ventilation space on all sides of the product.
  - Keep the ventilation area free of any objects that may restrict the airflow to the cooling components.
  - Do not place the product in enclosed compartments or areas with limited or no airflow.
  - Keep the ventilation openings clear and unblocked.
  - Do not fill the inner container with ice or liquids.
  - Never immerse the product in water.
  - Protect the product and its cables from heat and moisture.
- Remove the components with care during cleaning. Excessive force may cause damage to the components.
- To avoid damage, do not use bristle brushes, steel wire brushes, detergents, soap powders, alkaline detergents, benzene, gasoline, acids, acids, hot water, or any other corrosive or soluble items to clean the cabinet surface, door gasket, plastic decorative parts, and other components.
- Use a damp cloth to regularly clean the interior and surface of the product.
- Do not wash the product directly with water or soak it in water.
- Do not expose the product to rain for a long time.
- To ensure proper ventilation, regularly check and clean the product's air intake and exhaust vents to remove dust and debris.
- After cleaning, ensure the power cable is undamaged and dry before connecting it to the power supply.
- Take care to remove any residual moisture from electrical components with a dry, soft cloth or sponge before connecting to the power supply to prevent electric shock and short circuits.
- Transport the battery separately.



## Before Using the Refrigerator

1. If the refrigerator is laid on its side during transportation, make sure to keep it upright for at least 24 hours before turning it on. This ensures the compressor functions properly for regular use.
2. For any issues on first use, please contact us for assistance.
3. Pre-cool the empty unit before use to improve system efficiency.

## Application

- The product is intended to be used in household, outdoor, vehicle, marine, and similar applications, such as:
  - Staff kitchen areas in shops, offices, and other working environments;
  - Farm houses and by clients in hotels, motels, and other residential environments;
  - Catering and similar non-retail applications;
  - Outdoor camping use.
- This product should not be exposed to rain;
- Use on a flat and solid surface.



***BLUETTI shall not be liable for any equipment damage caused by the violation of the above instructions.***

## 2. Specifications

Model	F045D
Climate Class	SN / N / ST / T
IEC Protection Class	Class III
Refrigerator Capacity	40L / 42qt
Dimensions (L × W × H)	710 × 420 × 475mm / 28 × 16.5 × 18.7in (without wheels and draw bar) 738 × 440 × 475mm / 29.1 × 17.3 × 18.7in (with wheels and draw bar)
IP Rating	IPX4
Temperature Adjustment Range	-20°C - 20°C / -4°F - 68°F (@ an ambient temperature of 32°C / 89°F)
Rated Power (Refrigeration Mode)	65W
Rated Current (Refrigeration Mode)	8.5A / 4.0A
Rated Power (Ice-Making Mode)	140W
Rated Current (Ice-Making Mode)	10.5A / 5.5A
Refrigerant	R600a 0.71oz / 20g
Foam Vesicant	Cyclopentane (C5H10)
Net Weight	24kg / 52.9lbs

## Product Overview

- ❶ Door Latch (Refrigerator Compartment)
- ❷ Door Latch (Ice-making Compartment)
- ❸ Baskets
- ❹ Draw Bar
- ❺ Battery Compartment (also for storage purposes)
- ❻ Wheels
- ❼ Ice Shovel
- ❽ Ice Basket
- ❾ Control Panel
- ❿ USB Ports & DC Input
- ⓫ Handle
- ⓬ Drain
- ⓭ Drain Outlet (Pull out the plug to drain water and seal it well after draining)

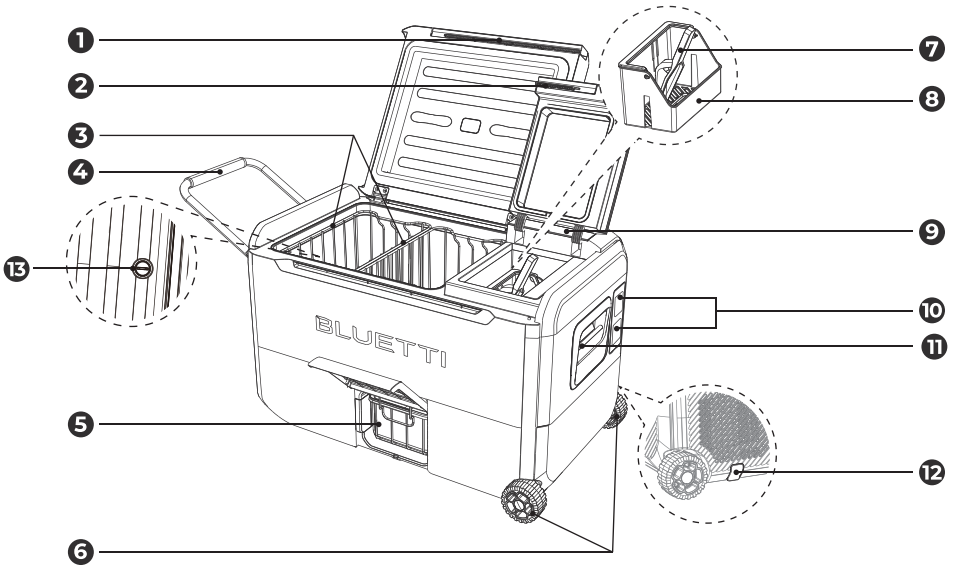



### 3. Packing List

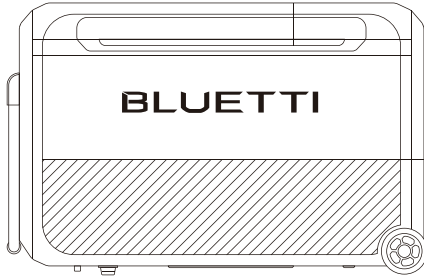

**F045D x1**

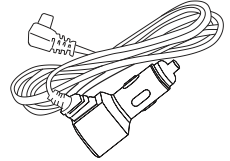

**Car Charging Cable**

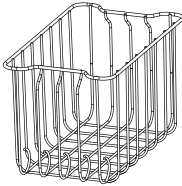

**Basket x1**

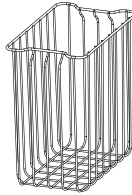

**Basket x1**

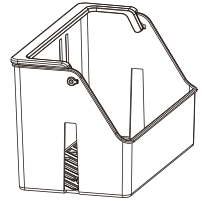

**Ice Basket x1**

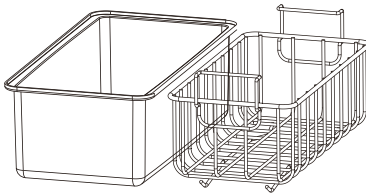

**Storage Basket & Box**

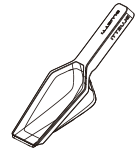

**Ice Shovel x1**

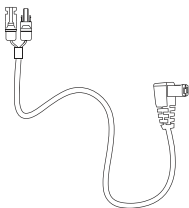

**Solar Charging Cable**

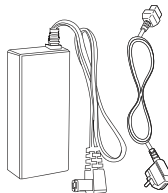

**152W AC Adapter  
& AC Power Cable**



**User Manual  
(warranty card included)**

## 4. Power Supply Connection

The F045D can work with four different power sources: AC mains, RV battery, B70 battery or other backup battery, and solar panel.

**Important Notice:** Check polarity when establishing the power supply connection. Use genuine adapters and cables provided by BLUETTI.

### 4.1 AC Mains (100V-240V / 50Hz/60Hz)

Connect the F045D to an AC outlet using the dedicated adapter and cable.

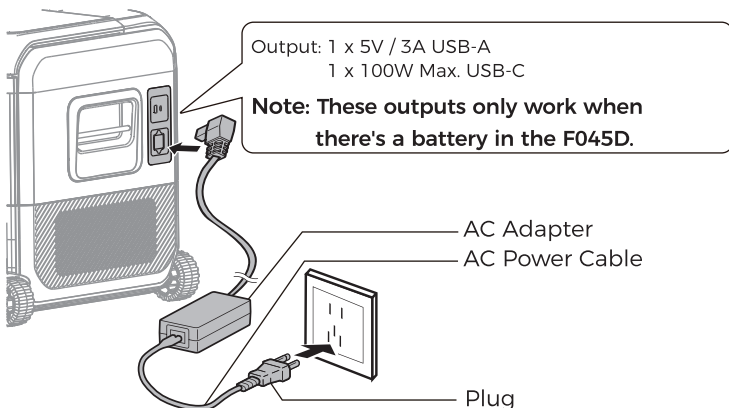

**Note:** Please choose the AC cable that is suitable for your country or region.

### 4.2 RV Cigarette Lighter

Connect the F045D to the vehicle's 12V / 24V cigarette lighter port via the car charging cable.

**Note:** If you are using the car cigarette lighter alone to power the refrigerator, it is recommended to start the car first to ensure stable battery voltage, so the refrigerator can continue to operate stably.

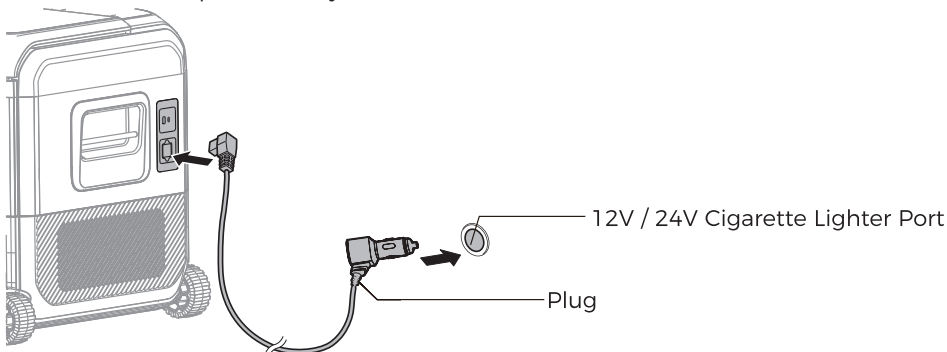

### 4.3 B70 Battery

Insert the B70 battery or backup battery into the F045D's battery compartment. Make sure the battery is properly connected to the unit's terminals. Securely close the compartment door.

**Note:** If you want to use third-party batteries, make sure they provide an output power of at least 120W (for 12V battery) or 152W (for 24V battery) to support the ice-making function.

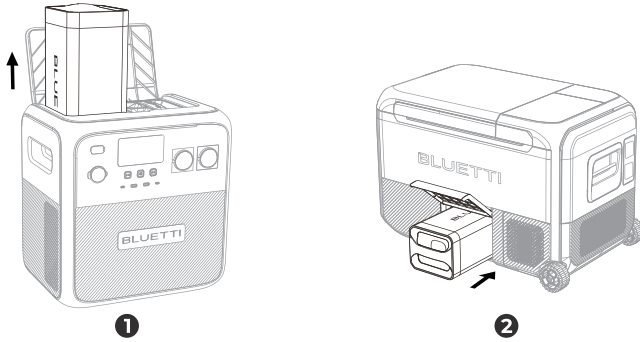

### Important Instructions

1. Handle the battery carefully when inserting or removing it.
2. Keep the interior of this compartment dry and clean, and protect it from water droplets or debris. This is especially important when using batteries to avoid short circuits and potential damage.
3. Before using the compartment, check the internal environment and make sure the door is closed when not in use to prevent contamination.
4. To avoid the risk of electric shock, be sure to keep children from touching the bottom terminals.
5. This compartment is designed to be used only with the storage basket and box provided. Do not use any other containers as this may cause damage.

**Customers will be responsible for any product-related issues or losses resulting from failure to follow the above instructions during operation.**

#### 4.4 Solar Panel (with battery inside)

Connect the F045D to the solar panel via the solar charging cable.

**Note:** After connecting to solar power, allow a 90-second wait for charging. Make sure your solar panel meets the following requirements:

Voc: 16V-28V      Current: 10A      Power: 200W Max.

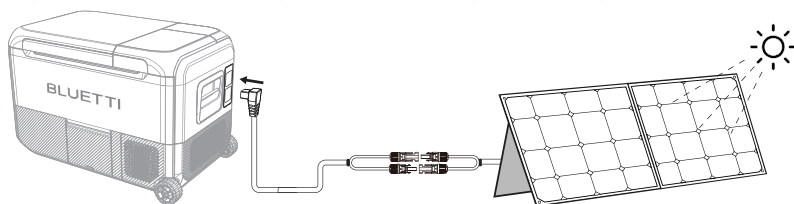

Highly recommended: 1 × BLUETTI PV200

#### 5. Lid Removal

- 1 Open the lid to an angle of about 30° (the scale line aligns with the side door).
- 2 Lift up the lid and remove it.

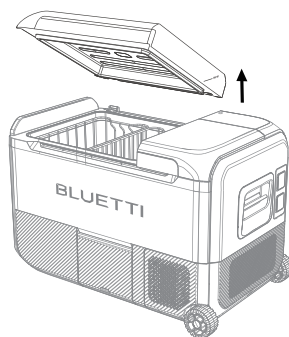
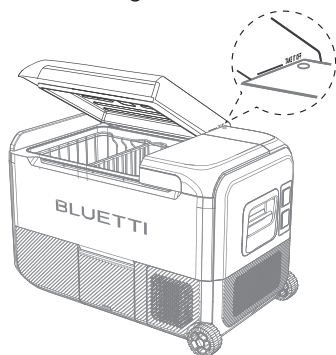

**Note:** Max load capacity of the lid: 50kg (110lbs)

#### 6. Water Volume (for ice-making)

The tank has an operating capacity of 400mL to 1000mL.

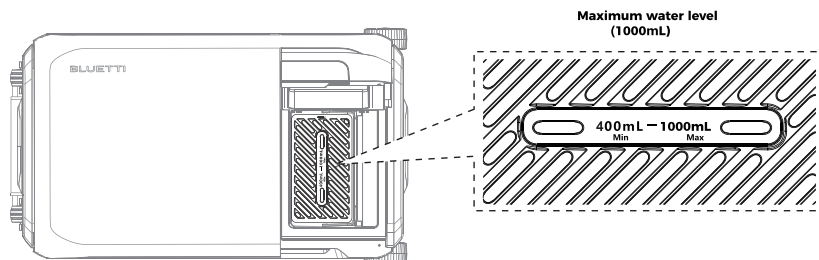

**Note:** If the water volume is less than 400mL, the ice cubes may be relatively small. On the other hand, if the volume is over 1000mL, the ice cubes may be submerged, resulting in a longer wait time for the first batch of ice cubes. Ensure the water does not enter the ice basket.

## 7. Refrigerator Compartment Operation

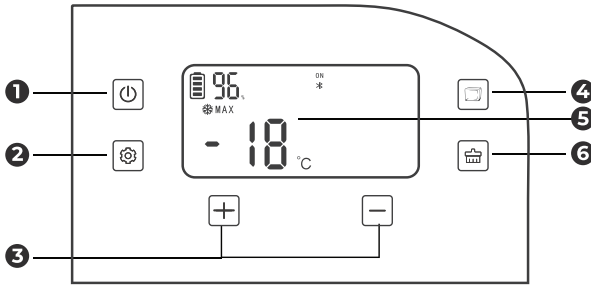



- |                       |                                   |
|-----------------------|-----------------------------------|
| ❶ Power Button        | ❷ Ice-Making Button               |
| ❸ Setting Button      | ❹ Refrigeration Mode Display Area |
| ❺ Temperature Setting | ❻ Self-Clean Button               |

**Note:** In Refrigeration Mode, the icons of Ice-Making Mode are not displayed.

### Power ON / OFF

- Tap and hold  for about 2 seconds to turn F045D on / off.

### Sleep Mode

- When you turn on the F045D, if you don't use it for 90 seconds, the display screen will automatically turn off. This indicates that it has entered Sleep Mode, and you'll see  on the screen.
- To wake it up, simply interact with any button to light on the screen, and then tap and hold  for about 2 seconds.

### MAX / ECO Mode Setting

- When the F045D is powered on, tap  once to enter the mode setting. Tap  or  to select between MAX and ECO modes.

### Temperature Setting

- Under the running state, tap  or  to adjust the refrigeration temperature.

### Temperature Unit Setting

- When the F045D is powered on, tap  twice to enter the °C / °F setting. Tap  or  to switch °C or °F.

### Bluetooth Setting

- When the F045D is powered on, tap  three times to enter the Bluetooth setting. Tap  or  to turn the Bluetooth on or off.

## 8. Ice-Making Compartment Operation

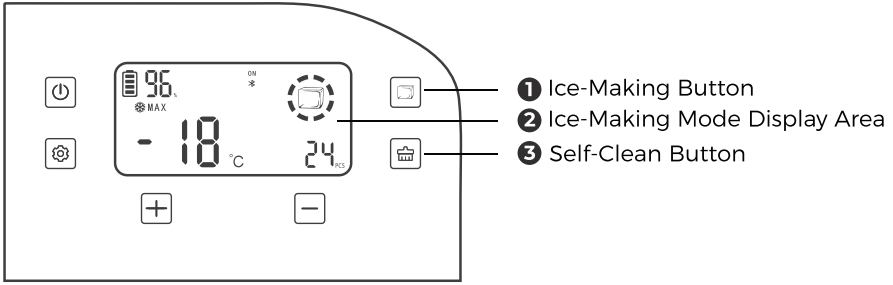

### Refrigeration / Ice-Making Mode Switch

- In the Refrigeration Mode, tap and hold  for 2 seconds to switch F045D to Ice-Making Mode, and vice versa.

### Ice-Making Mode Setting

- In the Ice-Making Mode, tap  to select **Single Ice** or **Continuous Ice** mode. When the ice making is completed, the F045D automatically switches to Refrigeration Mode.
  - In the Single Ice mode, the display shows "1" and then "24 PCS" ice cubes.
  - In the Continuous Ice mode, it shows "000" initially, then the specific ice cube count.
  - During the ice-making process, the progress indicator will flash. Once the ice-making is finished, the progress indicator will stop flashing.

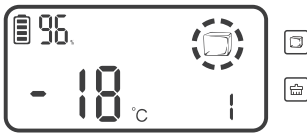

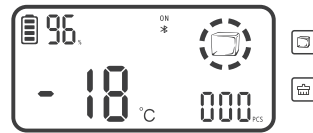

Single Ice





Continuous Ice

### Note:

1. The ice-making time depends on the amount of water and the ambient temperature. With 400 mL to 1000 mL of water, the first cycle usually takes about 20 minutes. In Continuous Ice mode, the second cycle will take 9-13 minutes if no extra water is added. It's important to note that if the ambient temperature exceeds 35°C, the second cycle may take longer, up to 15-23 minutes.
2. Do not forcibly remove the ice build-up; use forced defrost if needed (tap  and  simultaneously in Ice-Making Mode).

## Ice Size Setting

• In the Ice-Making Mode, when the ice cube icon flashes on the screen, you can tap  or  to switch between Large Ice and Small Ice.

**Note:** The Ice-Making Mode is set to make one batch of ice cubes at a time, and the size of the ice cubes is set to small by default.



Small Ice



Large Ice

## Self-Clean Mode

• In the powered-on state, tap and hold  for 2 seconds to initiate the automatic cleaning process. The  will remain lit.

- The cleaning process takes 20 minutes.
- When the cleaning is finished, the buzzer will sound for 5 seconds as a reminder.
- The Ice-Making Mode is not available during the process.

### Note:

1. The Self-Clean Mode is only available for the ice-making compartment. When the cleaning is finished, remove the drain plug and promptly drain the water. Then, tighten the drain plug securely to prevent leaks.
2. It's recommended to change the water every 24 hours and clean the inner chamber and the water tank every 3 days for optimum hygiene.

## Child Lock

• When the F045D is powered on, if there is no activity for 90 seconds, the screen will automatically light off, indicating that it has entered the Child Lock mode. You'll see  on the screen. During ice making and cleaning, the progress and status are displayed as shown in the following images:

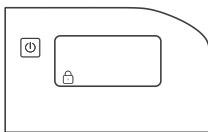

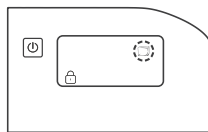

Refrigeration Mode

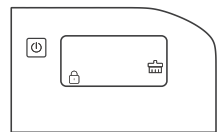

Ice-Making Mode



Self-Clean Mode

To unlock the Child Lock, tap any button to light up the screen. Then, tap and hold  for 2 seconds till  lights off.

## Water Shortage Reminder

• When the F045D detects insufficient water while making ice or self-cleaning, it prompts  and sounds a 5-second buzzer. If no water is added, it returns to Refrigeration mode.

## 9. BLUETTI App

With the BLUETTI app you have access to a range of functions including temperature control, Ice-Making Mode, Self-Clean Mode, and monitoring of operating status.

### 9.1 Download

Scan the QR code below to download the BLUETTI app, or search for "BLUETTI" in the App Store or Google Play.



BLUETTI App (iOS & Android)

### 9.2 Sign up

- 1 Open the app and tap **LOGIN / REGISTER**.
- 2 Tap **Sign up**.
- 3 Enter your email, the verification code, and tick the checkbox.
- 4 Tap **REGISTER** to create your BLUETTI account.

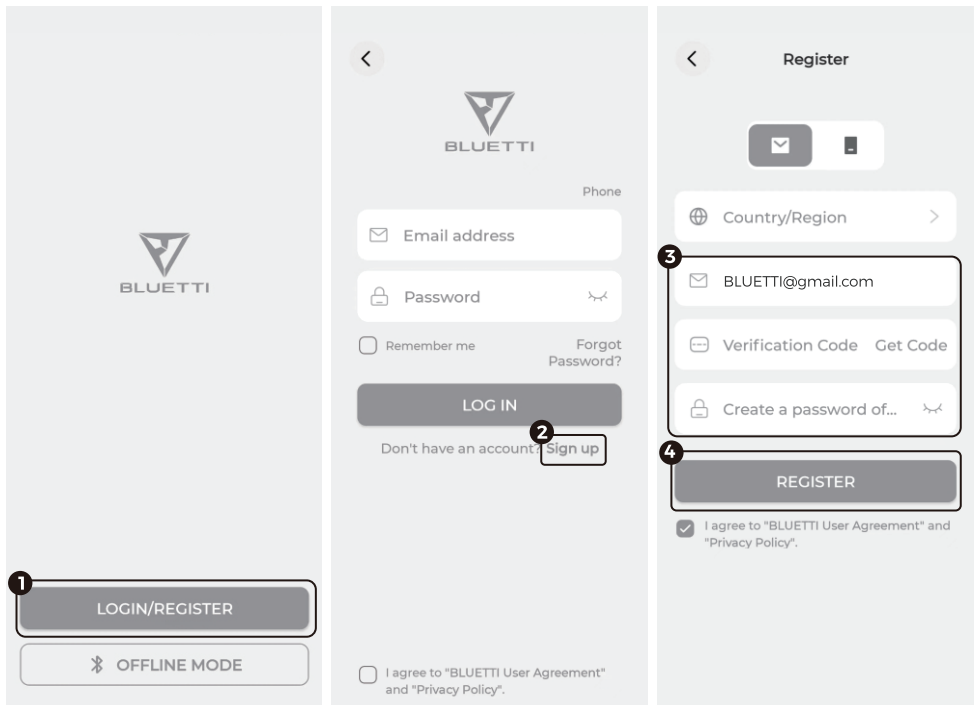



**Note:** If you don't receive the email with verification code, check your Junk or Spam folder. If you still can't find the email, try "Get Code" again, as there may be a delay. If the code is still unavailable, please contact BLUETTI customer service for assistance.

### 9.3 Log in

- 1 Open the app and tap **LOGIN / REGISTER**.
- 2 Enter your account details.
- 3 Tick the checkbox.
- 4 Tap **LOG IN**.

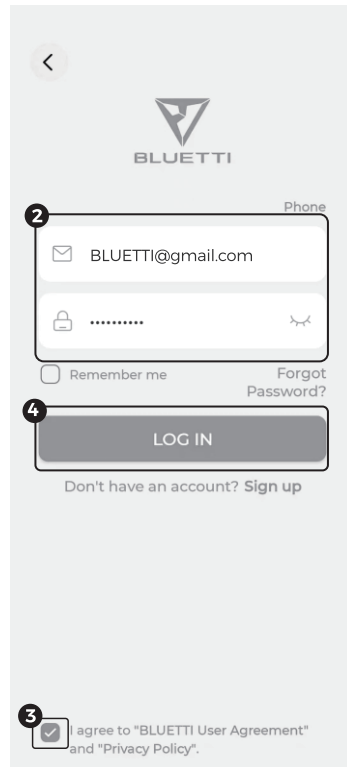
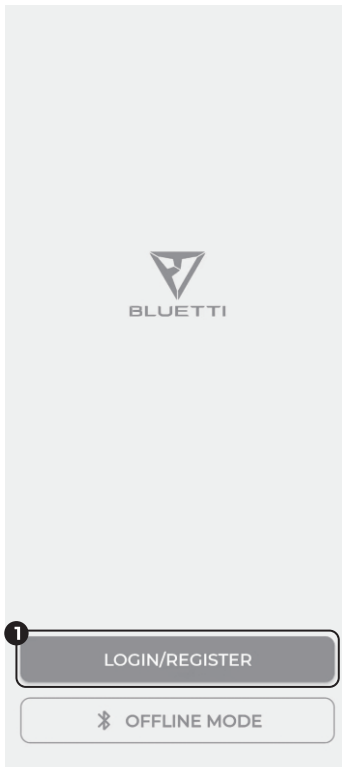

**Note:** If you forget your password, tap "Forgot Password?" to reset it.

## 9.4 Bluetooth Connection

**Note:** Make sure your F045D is powered on with Bluetooth enabled.

### Connection Method 1:

Go to the **Bluetooth** page and select your F045D (name starts with F045D) from the available list.

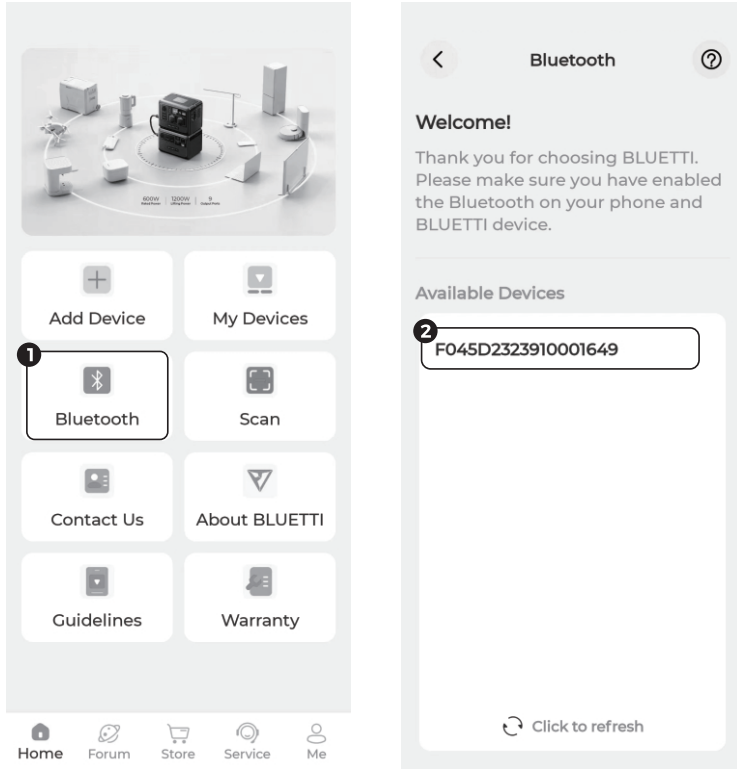

### Connection Method 2:

Go to the **Add Device** page, select your F045D and bind it to your account. Once successfully bound, navigate to **My Devices** page and then establish the connection.

For detailed instructions on how to control your F045D, follow the step-by-step instructions on the app.

## 10. Tilt Protection

Make sure that the F045D stands firmly on the surface when it is running. Keep the tilt **below 35°** for continuous use. If it exceeds 45°, the F045D safely shuts down. To restart, return the tilt to 35° or less. Between 30° and 45°, the product stays as it is, either running or shutting down.

## 11. Troubleshooting

When F045D experiences an abnormal condition, the screen will display an error code to indicate the specific issue. Please refer to the table below for helpful guidance.

Error Code	Error Description	Troubleshooting
E1	Battery low voltage protection (input voltage lower than the set value)	Check if the input voltage is within the operating voltage range.
E2	Fan overcurrent / fan short circuit / frequent start-stop	Unplug the product and let it sit for 5 minutes. If the issue persists, please contact BLUETTI Customer Service for assistance.
E3	Compressor motor startup error (motor stalling or excessive pressure difference in the refrigeration system)	
E4	Compressor motor speed too low (refrigeration system overloaded, motor unable to maintain the minimum speed of 1850r/min)	
E5	Compressor control module temperature too high or too low	Move the product to a well-ventilated and cool environment, let it sit for 5 minutes, and then restart. If the issue cannot be resolved, please contact BLUETTI Customer Service for assistance.
E6	NTC sensor malfunction (NTC open circuit or short circuit)	Check if the temperature sensor is loose or damaged. Contact BLUETTI Customer Service to arrange for a replacement or factory repair.
E7	Communication failure between the display control panel and the main board	Restart the product. If the issue persists or occurs frequently, please contact BLUETTI Customer Service.
E8	Tilt protection	Place the product on a level and flat surface, and let it sit for 5 minutes.
E9	High voltage alarm (DC input power supply $\geq 32V$ )	Adjust the DC input voltage between 24V and 28V. If the issue persists, please contact BLUETTI Customer Service for assistance.

## 12. Storage Tips



It's best to store fresh and frozen foods separately. Mixing them together can lead to the transfer of coldness from frozen items to other produce, causing unwanted temperature fluctuations.



To maintain freshness and prevent damage, it's recommended to store items like fruits and vegetables closer to the top of the basket. This area tends to be slightly warmer, reducing the chances of spoilage and protect them from being crushed by heavier items.



To prevent freezing and potential shattering, do not store glass bottles or liquids like beer, milk, juices, or soft drinks in the product when it is set at 0°C (32°F) or lower temperatures.



Minimize the time you keep the fridge or freezer door open to prevent warm air from entering. Plan ahead and decide which items you need to remove before opening the door. This helps reduce the exposure of the cabinet to warm air and maintains the desired temperature inside, ensuring optimal freshness and energy efficiency for your refrigerator.



To optimize the efficiency of your fridge or freezer, it's recommended to keep the cabinet as full as possible. A full cabinet consumes less power over 24 hours compared to a half-empty one. When the cabinet is filled with items, there's less air space, allowing the cold air to be trapped and retained. By doing so, you can optimize the cooling efficiency and performance of your refrigerator. However, if there is a significant amount of empty space, the coldness cannot be effectively captured and maintained.



When positioning the product at the rear of a car or trailer, it is advisable to avoid direct sunlight to minimize the risk of excessive heat. Additionally, ensure proper ventilation to maintain efficient power consumption and optimal performance. It's important to note that when a vehicle is parked outdoors under sunlight with an ambient temperature of 30°C (86°F), the interior temperature can reach up to 55°C (131°F).

### 13. FCC Warning (For North America)

Any Changes or modifications not expressly approved by the party responsible for compliance could void the user's authority to operate the equipment.

**Note:** This equipment has been tested and found to comply with the limits for a Class B digital device, pursuant to part 15 of the FCC Rules. These limits are designed to provide reasonable protection against harmful interference in a residential installation. This equipment generates uses and can radiate radio frequency energy and, if not installed and used in accordance with the instructions, may cause harmful interference to radio communications. However, there is no guarantee that interference will not occur in a particular installation. If this equipment does cause harmful interference to radio or television reception, which can be determined by turning the equipment off and on, the user is encouraged to try to correct the interference by one or more of the following measures:

- Reorient or relocate the receiving antenna.
- Increase the separation between the equipment and receiver.
- Connect the equipment into an outlet on a circuit different from that to which the receiver is connected.
- Consult the dealer or an experienced radio/TV technician for help.

This device complies with part 15 of the FCC Rules. Operation is subject to the following two conditions: (1) This device may not cause harmful interference, and (2) this device must accept any interference received, including interference that may cause undesired operation.

This equipment complies with FCC radiation exposure limits set forth for an uncontrolled environment. This equipment should be installed and operated with minimum distance 20cm between the radiator & your body.



## Warranty Policy

---

Thank you for choosing BLUETTI. Please read the terms and conditions and fill in the warranty card. This card, together with your proof of purchase, entitles you to the service of the product under the terms of this warranty.

The warranty period starts from the date of product receipt.

Item	Warranty Period
Portable Refrigerator and Freezer	24 months

The warranty does not cover:

- Issues arising after the warranty period has expired;
- Damage resulting from improper use, maintenance, or storage, contrary to the user manual;
- Unauthorized disassembly, repair, or modifications;
- Damage caused by force majeure events.



## Valid Proof of Purchase

---

- 01** Order number of the product purchased through authorized platform.
- 02** Invoice or order confirmation email, which includes product description, price, and sales channel.
- 03** To claim the warranty, provide multiple purchase proofs, such as receipts, shipping confirmation, product S/N, and photos or videos of the fault or issue.



## Return / Replace / Repair

---

BLUETTI warrants the product against defects materials and workmanship in normal use. During this warranty period, any defective parts or the entire product will be repaired or replaced at our discretion.

- 01** Contact us to obtain a return authorization first, or we may reject your return.
- 02** Return the product to the address provided. We'll cover the shipping cost.
- 03** Upon confirming receipt of the defective product, we'll proceed with the replacement in 7-10 business days.



## Warranty Policy

Customer:	Date:		
Company (optional):			
Address:	City:	State:	Zip:
Phone:	Fax:		
Email Address:			

Purchase From:
Receptionist:

<b>RMA #:</b>
---------------

Model:	
S/N:	
Purchase Date:	
Problem Description:	

**For more information, please visit:**

Web: <https://www.bluettipower.com>



@ BLUETTI Support

@ BLUETTI Official



@ bluetti\_inc



@bluetti.inc



@bluetti\_official



service@bluettipower.com

SalesContact (AU)

## HANECO XERO



1300 001 533

[info@haneco.com.au](mailto:info@haneco.com.au)

Address: 262 Marion Road,  
Netley, SA 5037 Australia

## SHENZHEN POWEROAK NEWENER CO., LTD.

Address: F19, BLD No.1, Kaidaer, Tongsha Rd No.168, Xili Street,  
Nanshan, Shenzhen, China

### Customer Service

Tel: 800-200-2980 (Monday to Sunday 9:00-17:00)

Email: [sale@bluettipower.com](mailto:sale@bluettipower.com) (Pre-sales),

[service@bluettipower.com](mailto:service@bluettipower.com) (After-sales)







**BLUETTI**

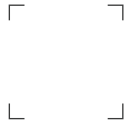

## **Certificate**

**Inspector:** \_\_\_\_\_

**QC:** \_\_\_\_\_

Just Power On





